

General information

Cavity

Type series: C0825

Dimensions and sectional view

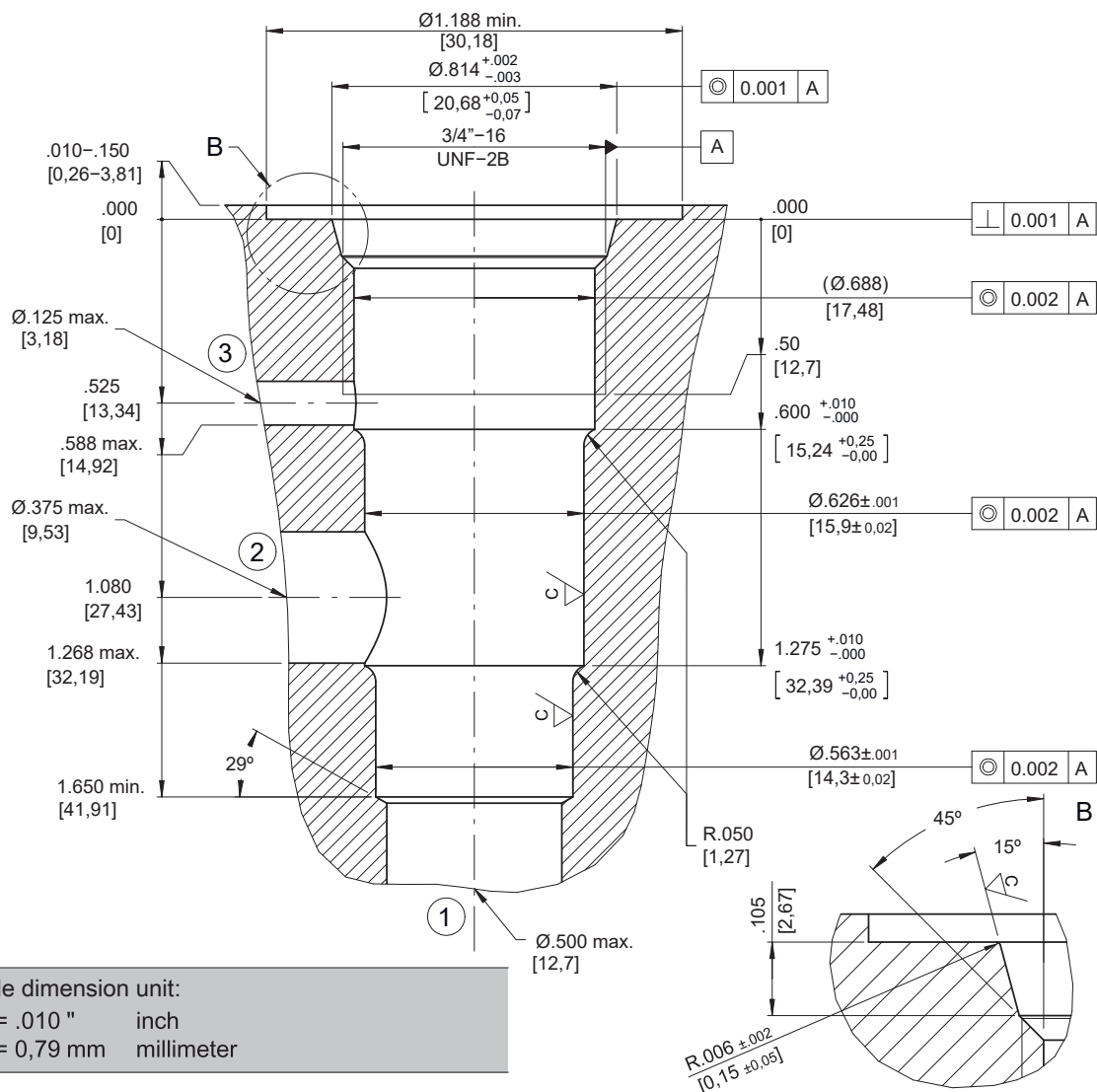

Example dimension unit:
.010 = .010" inch
[0,79] = 0,79 mm millimeter

Dimension Tolerances

Unless otherwise specified

0.000	$\pm .005''$
0.00	$\pm .010''$
Angles	$\pm 1/2^\circ$

Surface roughness

	C	D
Ra	45 μin (1.15 μm)	125 μin (3.2 μm)
	D	Unless otherwise specified

Installation information

**ATTENTION!**

You must maintain the specified positional and diametral tolerances. To ensure trouble-free operation of the screw-in cartridges, we strongly recommend that pilot drilling, boring, reaming and cavity thread-cutting are always performed in one setup.

**NOTE!**

Cavity type to factory standard.

**NOTE!**

We offer form tool sets for sale or hire. See data sheet 520-P-000050 for further information.